

The Model T Ford Ignition System & Spark Timing

By Ron Patterson and Steve Coniff

(This article first appeared in the Model T Times)

With the possible exception of the planetary transmission, no part of the Model T Ford's original design is more commonly misunderstood than the magneto ignition system. The purpose of this article is to simply explain how the Model T Ford ignition system and associated spark timing actually work.

The authors have been discussing this subject for some time, each approaching the project with differing objectives. Steve was interested in optimizing ignition timing for racing purposes and Ron wanted to write an article that would clearly explain the original Model T ignition system. Our peer reviewers challenged us. It was a convergence of interests and we all had great fun learning the truth about what we believed we already

understood.

Before we discuss the details of spark timing, let's review the unique features of the various components of the original Model T ignition system.

Figure 1 is an original Ford timer case and roller. This is important because there were many different manufacturers of timers other than Ford and they vary significantly in mechanical design and construction. The Ford timer case can be usually identified by the word "Ford" in script stamped into the main case near where the pull lever is affixed and the roller has similar markings on the spring loaded roller support arm, see Figure 2. The timer case has four electrical conductive metal segments mounted in a non-metallic insulator at equally spaced intervals around the inside circumference of the case. Each conductive segment has an insulated screw that extends outside the case perimeter forming a screw terminal with thumbnut where wiring to the coil box can be connected. The timer roller is mounted on the end of the camshaft, indexed with a pin and retained by a locking nut. The roller rides on the inner surface of the timer case connecting engine ground to each conductive



Figure 1—Ford Timer Case and Roller
Photo Courtesy of Steve Coniff



Figure 2—Ford Script on Timer Case and Roller.
Photo Courtesy of Steve Coniff



Figure 3—Timer Mounted on Engine
Using Original Ford Adjusting Gauge
Photo Courtesy of Steve Coniff

segment as it rotates thereby completing the electrical circuit to each coil.

Caution

Using this procedure with other than Ford timers may result in mis-adjusted timing, possible damage to the engine and injury to the operator.

Figure 3 shows the timer mounted on the engine and the original Ford adjusting gauge used to set the timer at

2.5 inches from the adjacent front plate mounting bolt. With the spark lever fully retarded (all the way up) the timer pull rod is appropriately bent to insert the end of the rod into the timer lever hole without changing the 2.5-inch measurement. As the steering column spark lever is moved through its quadrant, which consists of 28 notches, the timer case moves through its range of movement advancing the spark at a rate of approximately 2.85 crankshaft degrees per notch. This relationship is not exactly linear because of the angle of the pull lever on the end of the spark rod.

The construction of the Ford low-tension magneto is well understood and will not be described in further detail here. For those interested in the evolution of the flywheel magneto used on the Model T please refer to "Edward Huff, Henry Ford and the Flywheel Magneto" by Trent Boggess, Vintage Ford Magazine Volume 31 Number 2 March-April 1996. For the purposes of this discussion it is important to understand the basic electrical characteristics of the magneto output. The magneto output is an ac signal of varying voltage, frequency and current with eight complete cycles for each crankshaft revolution. The voltage varies over the normal range of engine speed from a low of 4 volts to a high of over 30 volts with sufficient current capacity to operate the coil. The sixteen positive and negative peaks of this signal are separated by 22.5 degrees of crankshaft revolution. The significance of this last point will be

explained later.

Figure 4 shows a portion of Model T flywheel drawing T-701-C (viewed from the transmission side). If you study this drawing carefully you will see the magnets are mounted on the flywheel in such a way that the magneto output is advanced from Top Dead Center (TDC) by 7 degrees of crankshaft rotation. (11 Degrees 15 Seconds minus 4 Degrees 15 Seconds equals 7 Degrees) The significance of the magnet mounting will be explained later. The Record of Changes for the flywheel drawings indicate the magnet mounting was unchanged for all Model T production.

The construction of the Model T ignition coil is well understood and will not be described in further detail here. For those interested in the evolution of the ignition coil used in the Model T please refer to the three part article entitled "The Model T Ignition Coil" by Trent Boggess and Ronald Patterson, Vintage Ford magazine Volume 34 Number 4, 5 & 6 July to October 1999. For the purposes of this discussion it is important to understand that proper operation of the coil points will affect ignition timing and hence engine performance. Additionally, the ignition coil operates entirely different when running on battery as opposed to magneto. When a properly adjusted ignition coil is running on battery and the roller grounds the timer segment, the coil will vibrate continuously and provide voltage to fire the spark plug. When a properly adjusted ignition coil is running on magneto and the roller grounds the timer segment the coil points respond to the individual current pulses of the magneto output to fire the spark plug. To reliably and consistently respond to the individual magneto current pulses and maintain accurate ignition timing the coil points must be carefully adjusted. The only way correct

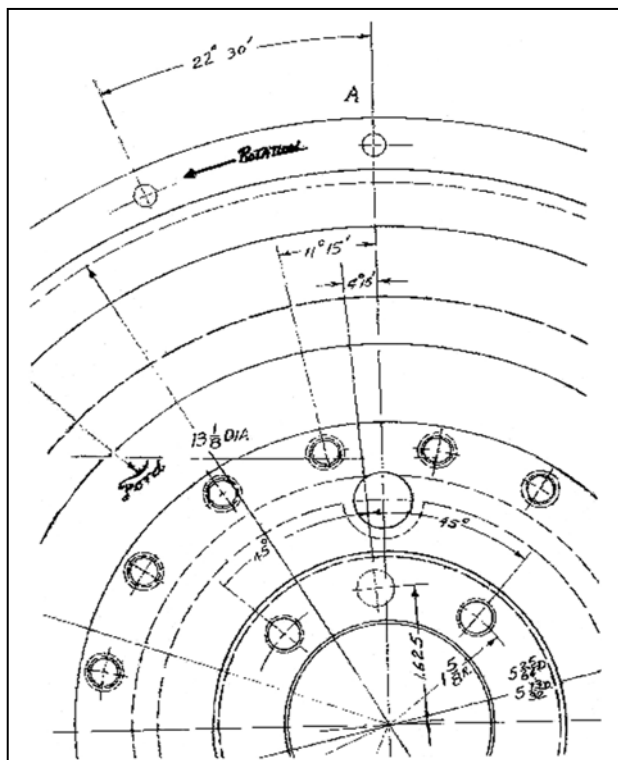

Figure 4—Flywheel Drawing T-701-C (partial)
From the Research Center collection of the Henry Ford Museum & Greenfield Village

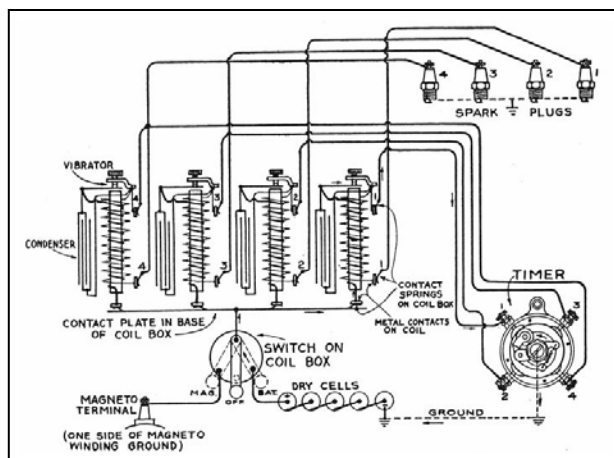

Figure 5—Simplified Diagram of Integrated Model T Ignition Components

Illustration from George W. Hobbs and Ben G. Consoliver *The Gasoline Automobile* 3rd Edition McGraw-Hill Book Company, Inc. NY 1924 P.163)

point adjustment can be attained is by using a hand cranked coil tester which simulates conditions very



Figure 6—Degree Wheel Mounted on Crankshaft, with Pointer
Photo Courtesy of Steve Coniff

similar to that which occur in the Model T ignition system when running on magneto.

Figure 5 is a simplified diagram of all the various ignition components integrated together as a system.

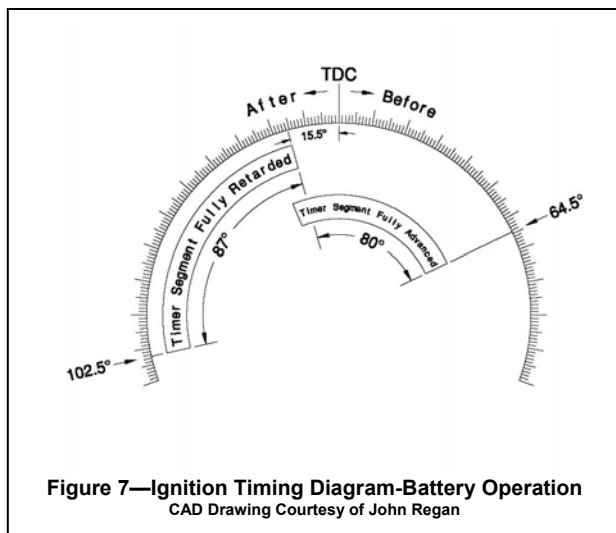

Figure 7—Ignition Timing Diagram-Battery Operation
CAD Drawing Courtesy of John Regan

Now lets discuss the detailed spark timing measurements we took.

Figure 6 depicts the method used to take the annular degree measurements. Remember, wherever the word “degree or degrees” is used hereinafter it is understood to mean “crankshaft degrees of rotation”. A degree wheel was mounted on the end of the crankshaft with a stationary marker pointing to the scale. TDC was located on cylinder one, the degree wheel indexed so the marker pointed to “0” degrees and fixed so the inter-relationship would not change as the crankshaft was rotated.

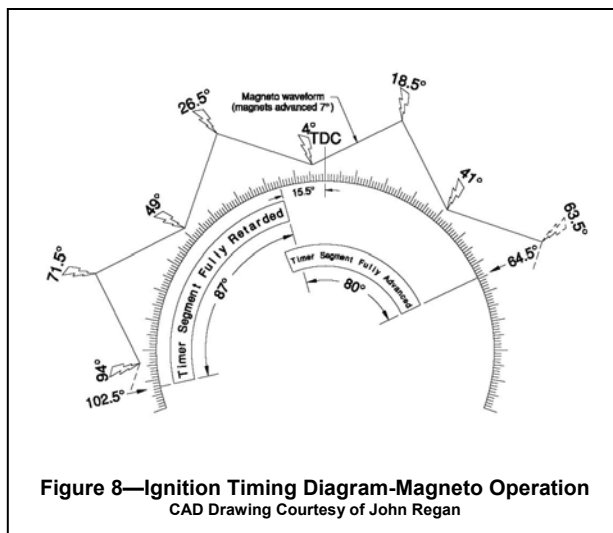

Figure 8—Ignition Timing Diagram-Magneto Operation
CAD Drawing Courtesy of John Regan

Figure 7 is a diagram depicting the first set of measurements. The engine front plate was checked for concentricity with the end of the camshaft. A reground Ford camshaft, good original Ford timer case and NOS timer roller were used to take these readings. The timer case was positioned using the Ford gauge. By manually rotating the crankshaft it was determined that the timer segment was grounded at 15.5 degrees after TDC and remained grounded for 87 degrees. As the timer case was moved through its range of the spark lever quadrant it was found the total advance of the timer case was 80 degrees.

As previously mentioned, when operating on battery, the ignition coil will vibrate continuously firing the plug as long as the timer segment is grounded. As you can see in Figure 7 the coil will continuously fire the spark plug starting at 15.5 degrees after TDC and cease at 102.5 degrees after TDC. As engine speed is increased and the spark lever advanced the coil will fire the spark plug throughout the degree range of the timer case movement until it reaches maximum advance of 64.5 degrees before TDC.

Figure 8 is a diagram depicting the second set of measurements. The test set up is unchanged and the intervals of timer segment and timer case movement are the same. When taking these measurements a properly rebuilt Model T coil was electrically connected to the timer, magneto and spark plug and the engine rotated at

600 RPM. An automotive ignition timing light was connected to the spark output to read the position of the degree wheel pointer to determine exactly where the coil fires in relationship to crankshaft position.

The magneto waveform depicted in Figure 8 is representative only and does not reflect the shape of the magneto waveform when viewed on an oscilloscope. But it does reflect the timing relationship attained by advancing the magnets on the flywheel by 7 degrees as indicated on flywheel drawing T-701-C. The spark symbols show the points where the ignition coil will fire on the magneto current output with respect to piston travel. Each of these locations is logically separated by 22.5 degrees.

When starting the Model T engine on the magneto with the spark lever fully retarded, the coil initially fires at 26.5 degrees after TDC. This is the nearest location based upon the timer case (spark lever) position where sufficient magneto current output is available. As engine speed is increased and the spark lever advanced the coil will initially fire at one of the additional locations where sufficient magneto current output occurs. These locations are 4 degrees after TDC, 18.5 degrees before TDC, 41 degrees before TDC and possibly 63.5 degrees before TDC. The spark depicted at 63.5 degrees before TDC spark may not occur depending upon the travel of the spark lever past the end of the quadrant.

Figure 8 helps explain why it is easier to start a Model T on magneto when the spark lever is advanced a few notches. By advancing the spark lever the coil will fire at 4 degrees after TDC. If the magnets were not advanced 7 degrees the coil would initially fire at 11.25 degrees after TDC.

Figure 8 also helps explain why the engine sometimes speeds up when switching from battery to magneto. There are locations of spark lever setting when running on battery that will result in more optimal spark timing when switched to magneto.

Summary

As you can see in Figure 7, when running on battery, linear spark timing can be obtained by moving the spark lever. This would appear best for optimum engine performance, but Model T coils do not work well on the 6 volt battery at higher engine speeds.

As you can see in Figure 8, when running on the magneto, timing advance is not linear. The spark lever is a selector that, when moved, determines the magneto current pulse where the ignition coil will supply spark voltage to the plug.

The authors would like to formally thank Bruce McCalley, Trent Boggess and John Regan for their review of drafts of this article. Without their detailed knowledge, critical eye and encouragement, this article could not have been completed.

The authors may be contacted by writing:

Ron Patterson
8 Olde Surrey Lane
Medway, Massachusetts 02053
508-533-5222
modeltcoils@sprynet.com

Steve Coniff
1020 West Woodman Road
Colorado Springs, Colorado 80919
719-594-9311
sconiff@codenet.net